

# CNC車殼飾蓋安裝說明書

## CNC DECORATED COVER FOR SCOOTER COVER INSTALLING MANUAL

步驟2:依序放入內層與外蓋，在以內六角螺絲M5x0.8x12MMx6PCS鎖緊於底座上  
 STEP 2. PUT INNER PIECE & COVER, SCREW WITH HEX SOCKET BOLTS M5\*0.8\*12MM\*6PCS ON THE BOTTOM POST.

步驟1:先將底座以內六角螺絲M6x1.0x16MM x1PC鎖緊於車體上  
 STEP 1. SCREW BOTTOM POST WITH HEX SOCKET BOLTS M6\*1.0\*16MM\*1PC ON THE SCOOTER.

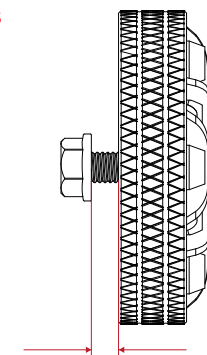
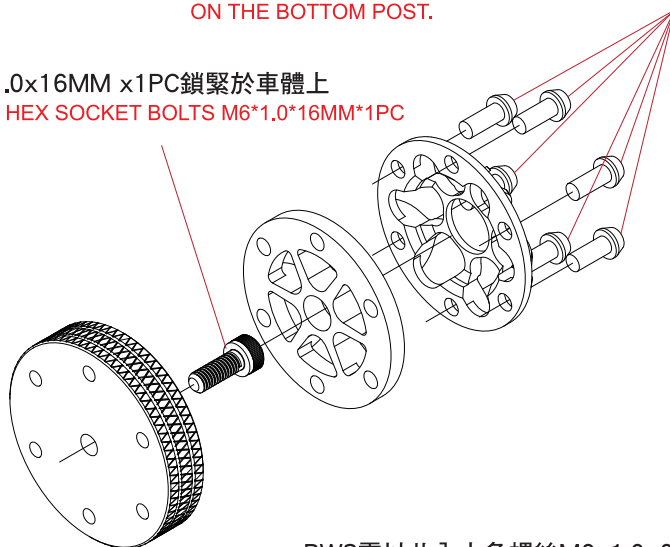
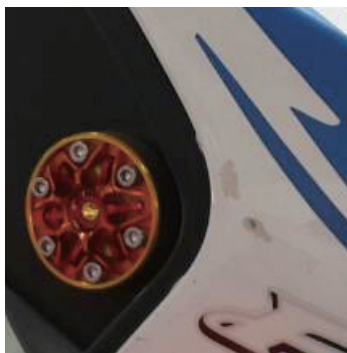

螺帽與螺絲切齊後尚餘5MM的空間  
 車殼厚度不大於5MM的地方皆可任意安裝  
 THERE IS STILL 5MM SPACE BETWEEN NUT & BOLT.  
 IF THICKNESS OF SCOOTER COVER IS NOT OVER 5MM,  
 CNC DECORATED COVER CAN BE INSTALLED AT ANY PLACE.

BWS需以此內六角螺絲M6x1.0x30MMx1PC安裝  
 FOR BWS 125, PLEASE CHANGE TO HEX SOCKET BOLTS M6\*1.0\*30MM\*1PC.

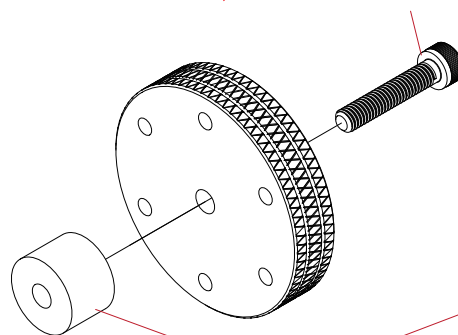

BWS需安裝此套管  $\phi 6.2 \times \phi 20 \times 14\text{MM} \times 1\text{PC}$   
 FOR BWS 125, NEED TO INSTALL WITH BUSH  $\phi 6.2 \times \phi 20 \times 14\text{MM} \times 1\text{PC}$ .